



CONVEYOR COMPONENTS COMPANY

Division of Material Control, Inc.

130 Seltzer Road, PO Box 167 • Croswell, MI 48422 USA

PHONE: (810) 679-4211 • TOLL FREE (800) 233-3233 • FAX: (810) 679-4510

Email: info@conveyorcomponents.com • <http://www.conveyorcomponents.com>

MODEL RS: ROPE SAFETY CONTROL INSTALLATION INSTRUCTIONS

WARNING:

DEATH or SERIOUS INJURY may occur.

Before installing or adjusting, shut down and physically lock-out the conveyor system.

TECHNICAL INFORMATION

Raintight units (standard):

Enclosure type 1, 3, 3R, 4 and 4X dust-tight and rain-tight construction with corrosion resistance.

Gasket sealed for indoor/outdoor applications.

Aluminum housing with 3 conduit openings in base casting.

Dual Rated Units:

Enclosure type 1, 3, 3R, 4 and 4X dust-tight and rain-tight construction, also for use in Class II, Groups E, F & G and Class III Hazardous Locations.

Aluminum housing with 3 conduit openings in base casting.

Explosion Proof units:

Enclosure for use in Class I, Groups C & D; and Class II, Groups E, F & G, and Class III Hazardous Locations.

Aluminum housing with 3 conduit openings in base casting.

Ambient Temperature Range (hazardous locations units): -50°C to 40°; -58°F to 104°

Electrical Ratings:

<u>SPDT switches:</u>	<u>DPDT switches:</u>
20 Amps, 125/250/480 VAC	15 Amps, 125/250 VAC
10 Amps, 125 VAC Inductive	N/A
1 hp, 125 VAC	3/4 hp, 125 VAC
2 hp, 250 VAC	1 1/2 hp, 250 VAC
1/2 Amp, 24 VDC	N/A
1/2 Amp, 125 VDC	N/A
1/4 Amp, 250 VDC	N/A

Note: Special units with gold plated micro-switch contacts rated 0.1 Amps at 125 VAC.

Micro-switch(es) may be wired for single throw operation, either normally open or normally closed as required. See figure 1.

Figure 2: Electrical Terminals

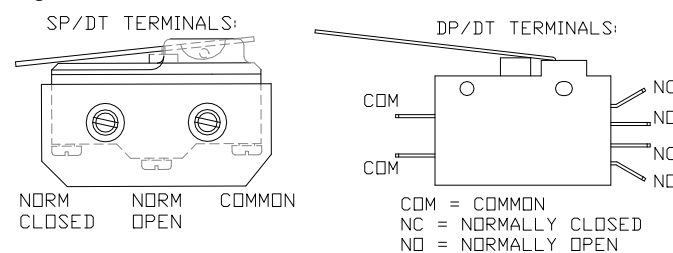
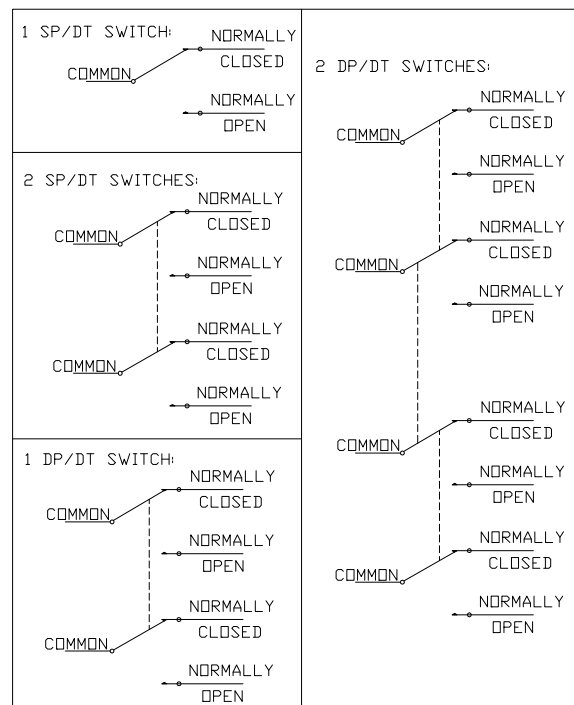

Figure 1: Contacts



INSTALLATION INSTRUCTIONS

1. The base should be mounted on a flat surface using the three (3) mounting holes in the base casting (see figure 3). The holes in the base are manufactured for 3/8" bolts.
2. Each unit can cover a maximum of 200 feet of conveyor – 100 feet in each direction. Safety considerations dictate that not more than 100 feet of cable should be attached to each side.
3. The eyebolts supporting the cable should be placed at intervals from 8' – 10'. Care must be taken that the cable does not become too slack. However, if the cable is too tight, false actuation of the unit may occur.
4. Field wiring must meet or exceed the requirements of the National Electrical Code and any other agency or authority having jurisdiction over the installation. Conduit fittings must meet applicable CSA and UL standards.
5. This unit is designed for pilot duty. The control circuit should be wired through the motor starter circuit of the conveyor or other equipment to be controlled. Do not wire the unit directly into a heavy duty motor circuit. See "Switch" information on front page. Note: TWIST WIRES TOGETHER BEFORE INSERTING IN TERMINAL (ENROULEZ LES FILS ENSEMBLE AVANT LES INTRODUITE DANS LA BORNE.).
6. The control should be tested after installation by actuation of the cable. The protected equipment should stop and alarms should sound as required with a minimum effort on the cable. Cable tension can be adjusted as necessary by changing the location of the cable on the handle (see figure 4).

Figure 4: Cable Positions

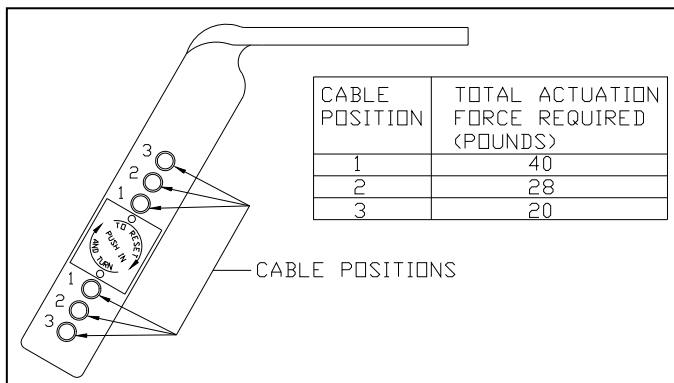

Figure 3: Control Dimensions

