

INSTALLATION INSTRUCTIONS *MAG-NEAT-O™ MAGNETICALLY COUPLED MOTION CONTROL*



Please read and save these instructions. Read carefully before attempting to assemble, install, operate or maintain the product described. Protect yourself and others by observing all safety information. Failure to strictly follow all instructions may result in DEATH or SERIOUS INJURY. Before servicing, shut down and physically lock-out the conveyor system. Disconnect power before servicing.



Conveyor Components Company

Division of Material Control, Inc. | Crosswell, Michigan U.S.A.

MAG-NEAT-O™ MAGNETICALLY COUPLED MOTION CONTROL



WARNING! STRONG MAGNET

May interfere with pacemakers or other implantable medical devices.

Pinching Hazard: Attracted to other magnets and metal devices.

May cause damage to credit cards, watches, data storage devices or other sensitive electronic devices.



WARNING! This product is not designed or intended as a substitute for machine guarding.



WARNING! Always follow applicable requirements for Personal Protection Equipment.

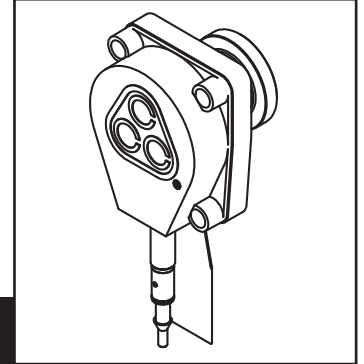

OPERATION

The **MAG-NEAT-O™** is a pulse encoder designed to be magnetically installed on rotating shafts without drilling or tapping the shaft on center.

INSTALLATION



WARNING! Failure to strictly follow all instructions may result in DEATH or SERIOUS INJURY. Before servicing, shut down and physically LOCK-OUT the conveyor system. Disconnect power before servicing.

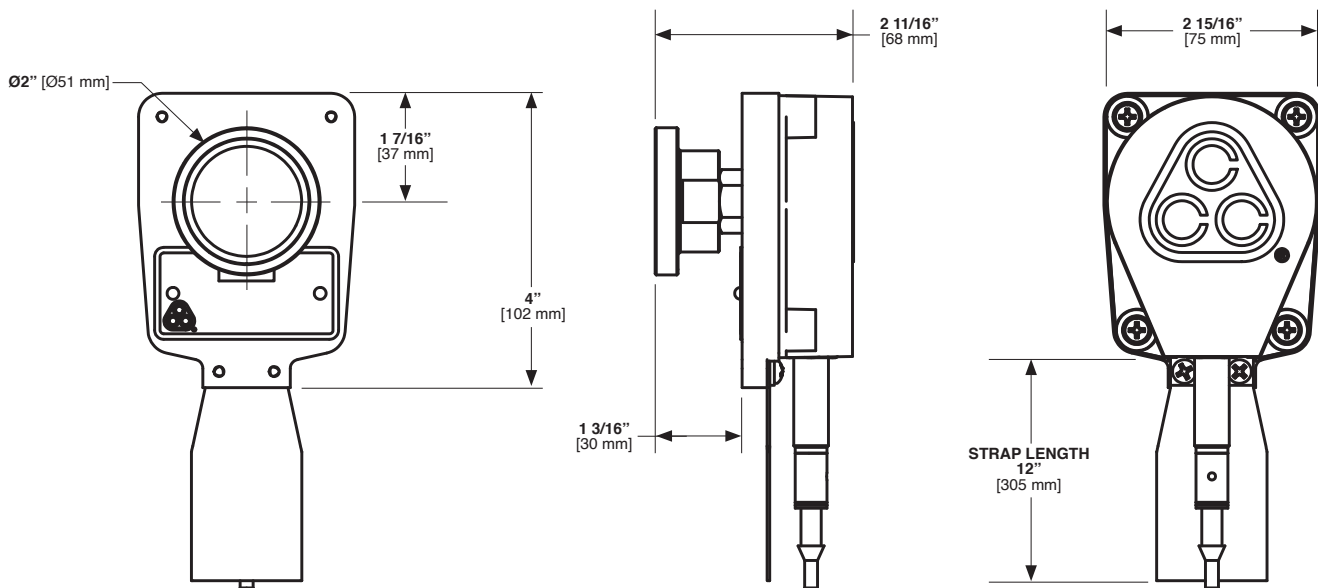

INSTALLATION INSTRUCTIONS *MAG-NEAT-O™ MAGNETICALLY COUPLED MOTION CONTROL*

MOUNTING

1. Make sure the shaft end is clean and free from obstruction.
2. Make sure the shaft end is flat and true.
3. Remove the protector plate from the magnetic coupling.
4. Place the **MAG-NEAT-O™** at the center of the machine shaft. It should magnetically adhere.
 - a. For nonmagnetic shafts and shafts smaller than 1-7/8", install the protector plate onto the end of the shaft. Use countersunk screws so that the magnetic coupling sits flush against the plate.
5. Secure the retention strap to reduce the risk of damage from accidental dislodging of the **MAG-NEAT-O™** from the shaft. The sensor body should hang within 20° of vertical. Trim excess strap.
6. In applications with risk of impact from falling material or moving equipment, guarding may be required to prevent damage or dislodging of the **MAG-NEAT-O™**.

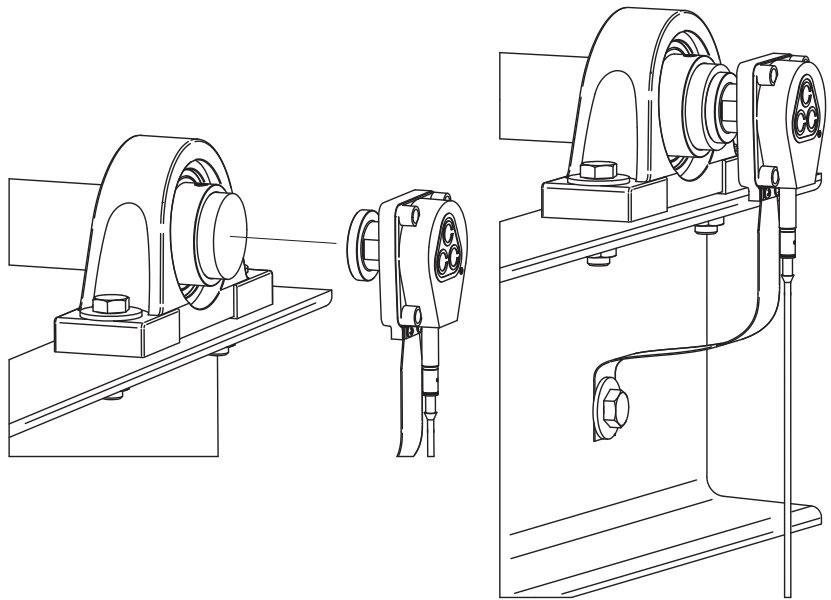

WIRING

Use the table below when wiring the **MAG-NEAT-O™** to a Conveyor Components Company speed controller.

MODEL	OPTIONAL CONTROLLER	SENSOR CONDUCTOR COLOR	CONTROLLER TERMINAL	SETTINGS/PROGRAMMING
MCM-2S	RMS Series Controller	White / Brown	P	Refer to RMS Controller Instructions
		Black / Blue	N	
MCM-3S	MSD-800 Series Controller	Brown	6	Refer to MSD Controller Instructions. To display RPM, Pscale = 10
		Black	12	
		Blue	11	

Use the wiring diagram below when connecting to any other controller.

MCM-2S

2-WIRE SENSOR
10-55 VDC INPUT
400mA OUTPUT

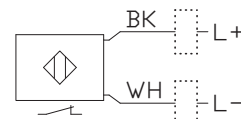
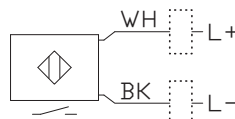

ALTERNATE SENSOR
10-30 VDC INPUT
<100mA OUTPUT

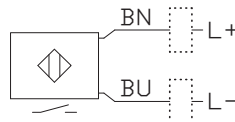

MCM-3S

3-WIRE SENSOR
10-30 VDC INPUT
<200mA OUTPUT, NPN

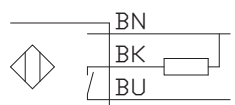

INSTALLATION INSTRUCTIONS *MAG-NEAT-O™* MAGNETICALLY COUPLED MOTION CONTROL

MAINTENANCE

Periodically inspect the **MAG-NEAT-O™** for damage, or obstruction. Ensure it is securely mounted and the bearing rotates freely.

SPECIFICATIONS

Sensor	MCM-2S	2-wire inductive proximity sensor 10-55 VDC, 400mA, PNP/NPN	Alternate Sensor: 10-30 VDC, <100mA, NPN
	MCM-3S	3-wire inductive proximity sensor: 10-36 VDC, <200mA output, NPN	
Controller	MCM-2S	RMS series controller or other user supplied Controller (PLC, DCS, direct output, etc.).	
	MCM-3S	MSD-800 series controller with readout or other user supplied Controller (PLC, DCS, direct output, etc.).	
Max RPM	2,000 RPM		
Scaling Factor	1Hz =	10 RPM	

TROUBLESHOOTING

No signal from sensor:

- Verify the wiring connections.
- Verify that the sensor is receiving power. The LED on the sensor should blink as the shaft is rotated.
- Verify whether your controller is set up for NPN or PNP input. (Only the 2-wire sensor can be configured for PNP output. (See wiring diagram).

Signal is irregular:

- Observe the LED on the sensor while rotating the shaft. The LED should blink 6 times per rotation. If the LED is not blinking 6 times per rotation, remove the cover and adjust the probe closer to the target wheel. Make sure the probe is secure before replacing the cover.

The sensor detached from the shaft:

- Check for signs of impact from falling material or moving equipment. Guarding may be required to prevent future impact.
- Verify that the shaft end is flat, true, and free from debris.
- * Verify that the sensor is applied to the center of the shaft.
- Verify that the shaft diameter is $\geq 1\text{-}7/8$ " [48 mm] and is sufficiently magnetic. See installation section for how to accommodate undersized or non-magnetic shafts.
- Magnetic strength is reduced at elevated temperatures. Some magnetic strength can be permanently lost if the magnet exceeds 80°C [176°F].
- Verify that the bearing is free spinning.

Excessive vibration:

- Verify that the shaft end is flat, true, and free from debris.
- Verify that the sensor is applied to the center of the shaft.
- Verify that the bearing is free spinning.

Sensor leans or rotates while in operation:

- Verify that the bearing is free spinning.
- Verify that the tether is appropriately secured.

For other inquiries, call Conveyor Components Company Customer Support at (810) 679-4211.



Conveyor Components Company

Division of Material Control, Inc. | Crosswell, Michigan U.S.A.

(810) 679-4211 • conveyorcomponents.com
©Copyright Conveyor Components Company. 2022
Division of Material Control, Inc.