

MODEL BA

HEAVY DUTY BELT ALIGNMENT CONTROL PREVENTS CONVEYOR BELT RUN-OFF



MODEL BA-2X
(EXPLOSION PROOF)

- Inexpensive protection for conveyor belts.
- Easy to install. Can be bolted directly to discharge chute or mounted to conveyor frame.
- Stainless ball bearings, spring, and pivot.
- UL and CSA Listed switches: weather tight or explosion proof.
- Rugged and durable — not a light duty “whisker” switch.

PROTECTS VALUABLE CONVEYOR BELTS FROM SEVERE DAMAGE

Model BA heavy duty conveyor belt alignment control protects valuable conveyor belts from severe damage due to belt misalignment or run-off. The Model BA makes sure that the belts are tracking properly. Prevents costly down time and unnecessary maintenance expense. Designed especially for bulk handling conveyor applications, it maintains a safeguard over equipment and keeps conveyor belts running.

Sometimes called a “side slip switch” or a “belt misalignment switch,” the Model BA operates on a very simple principal. Two controls are positioned close to the belt, one on each side, so that undesirable side to side motion of the belt will contact a switch roller. The roller “gives” just enough to actuate the switch. The signal generated by the actuated switch can be used to take appropriate action to re-align the conveyor belt, thus eliminating conveyor damage and serious down time.

CONSTRUCTION AND OPERATION

The Model BA belt alignment control has two basic welded steel components. The base housing and the roller housing. The roller housing contains the sensing roller and is attached to the base housing with a stainless steel pivot. The stainless steel pivot assures that movement will not be inhibited by corrosion. The roller and roller housing together are designed to pivot slightly when the roller is touched by the conveyor belt. The roller housing assembly actuates an enclosed switch mounted at the bottom of the base housing, it moves approximately 1/4” to actuate the switch. A stainless steel spring is mounted with a bolt at the bottom of the roller assembly to hold it away from the control except during actuation.

Microswitches are housed in either the standard weather-tight, or optional explosion proof enclosures.

The roller has stainless steel ball bearings and nylon labyrinth seals to prevent corrosion and entry of water or dirt.

OPTIONAL BREAKAWAY MOUNT

This optional feature allows the Model BA to give a signal, and then to get out of the way if the belt does run-off, preventing serious damage to switches and belts. The breakaway mount is spring loaded and automatically returns the Model BA to its original position when the conveyor belt is realigned. It is designed so that the Model BA roller assumes a horizontal position when the breakaway mounting is actuated.

Breakaway mount is available with an optional microswitch to indicate the breakaway condition has occurred. Thus, two signals can be generated: First, a signal from the Model BA unit that the belt has deviated. Second, a signal from the breakaway switch that the belt has deviated further.

BA-55



MODEL BA DIMENSIONAL INFORMATION

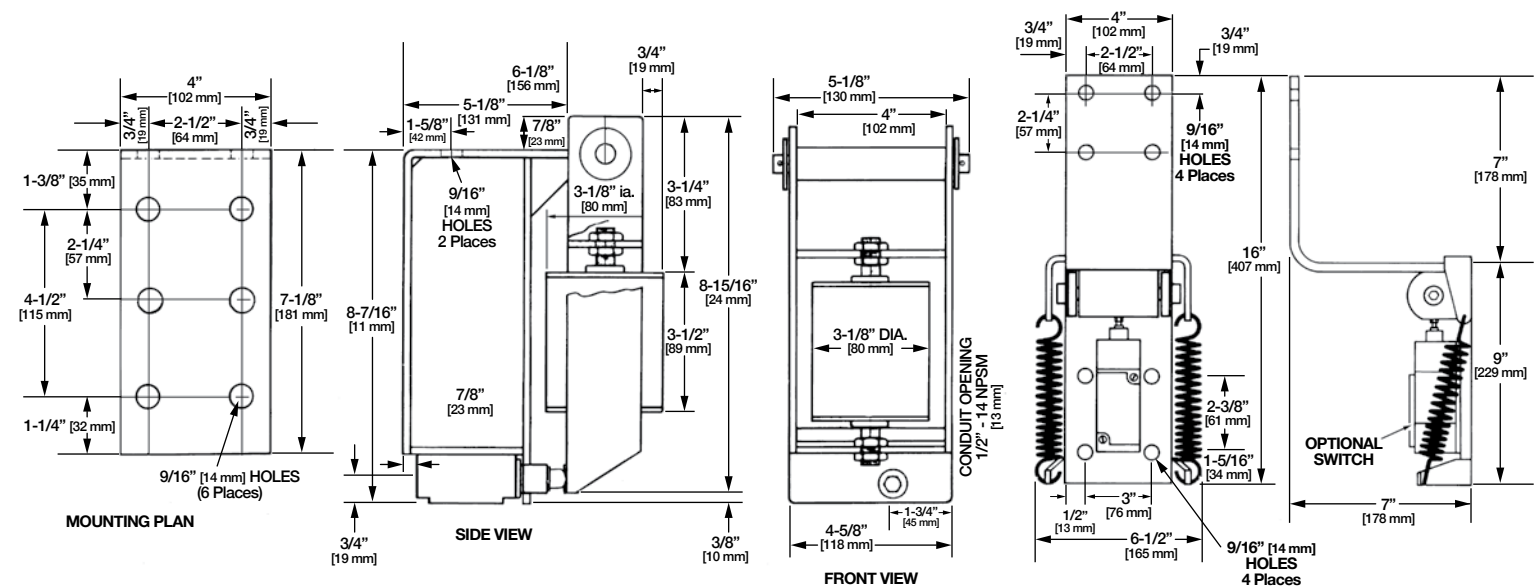

MODELS

MODEL	DESCRIPTION	ELECTRICAL RATING (BELOW)	SHPG. WT. LBS.
BA-1	1 Single Pole Double Throw (SP/DT) Microswitch*	1	18
BA-1X	1 Single Pole Double Throw (SP/DT) Microswitch**	3	18
BA-2	1 Double Pole Double Throw (DP/DT) Microswitch*	2	21
BA-2X	1 Double Pole Double Throw (DP/DT) Microswitch**	2	21

*GENERAL PURPOSE NEMA TYPE 1,3,4 & 13
**EXPLOSION PROOF NEMA TYPE 7: Class I, Groups C, D; Type 9: Class II, Groups E, F, G

MODEL BA - ACCESSORIES

MODEL	DESCRIPTION	SHPG. WT. LBS.
BA-5*	Optional “Break Away” Mounting	10
BA-55*	Optional “Break Away” Mounting with additional SP/DT Microswitch	15
BA-55X*	Optional “Break Away” Mounting with additional Explosion Proof SP/DT Microswitch	15

*BA Belt Alignment Control purchased separately

NUMBER OF UNITS RECOMMENDED

No less than four alignment controls should be installed on each conveyor, one on each side of the belt near the head and tail pulleys. For longer conveyors, we recommend an additional pair every 250 to 500 feet.



Shown are two BA units protecting a valuable conveyor belt from damage due to belt misalignment or run-off at an aggregate facility

SWITCH ELECTRICAL RATINGS

1. 20 Amp @ 125, 250, or 480 VAC;
10 Amp @ 125 VAC “L”; 1 HP @ 125 VAC;
2HP @ 250 VAC; 1/2 Amp @ 125 VDC;
1/4 Amp @ 250 VDC.
2. 10 Amp @ 125 or 250 VAC; 0.3 Amp @ 125 VDC;
0.15 Amp @ 250 VDC
3. 10 Amp @ 125, 250 or 480 VAC;
1/2 Amp @ 125 VDC; 1/4 Amp @ 250 VDC.

